

Food Equipment (NZ) Ltd

1066 Hinemoa Street, Rotorua

P.O. Box 10067, Rotorua, New Zealand

(07) 3488430



Under Counter Refrigerator

Model NO.: GN3100



Food Equipment (NZ) Ltd

1066 Hinemoa Street, Rotorua

P.O. Box 10067, Rotorua, New Zealand

(07) 3488430



Specification

Dimensions	1800 x 700 x 850 mm
Gross Volume / Net Volume	417 / 402 Liter
Temperature Range (°C)	0 to +10
Ambient	T
Doors	3 solid / auto-closing
Shelf	3 ,GN1/2
Voltage / Frequency (V/Hz)	220 – 240 / 50
Input Power (W)	300
Compressor (HP) /Gas	Embraco /R134a
Type of Cooling	fan assisted
Type of Defrost	automatic
Controller	digital
Body Constuction	Stainless Steel
Condenser	Pure Cooper
Wheel	Castor

** All Guzzini products must pass numerous quality control inspections throughout the manufacturing process.*

** All Guzzini products are operated and monitored for a minimum of thirteen hours prior to packaging and shipping.*

** All Guzzini Products are CE& IEC approved .*

** All Guzzini products come with full one year parts warranty*

Features

Food Equipment (NZ) Ltd

1066 Hinemoa Street, Rotorua

P.O. Box 10067, Rotorua, New Zealand

(07) 3488430



- * *Energy saving controller ensures accurate temperature control*
- * *Designed for effective operation in high ambient 43 ° C environments, and built to withstand the rigours of day-to-day operation*
- * *Construction includes polyurethane insulation with zero ODP and low GWP, providing excellent thermal efficiency*
- * *Strong stainless steel body construction*
- * *Removable racking and nylon coated shelving for flexibility and ease of cleaning*
- * *Removable cassette refrigeration system for easy servicing*

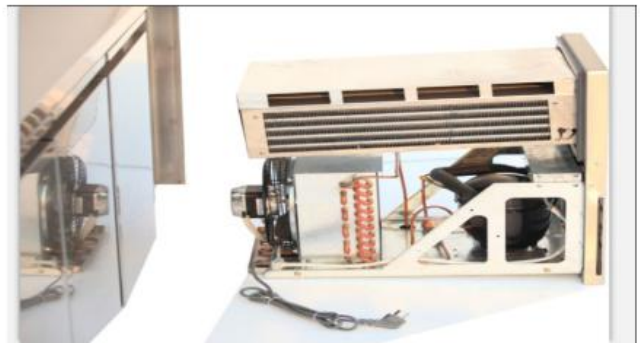

Food Equipment (NZ) Ltd

1066 Hinemoa Street, Rotorua

P.O. Box 10067, Rotorua, New Zealand

(07) 3488430

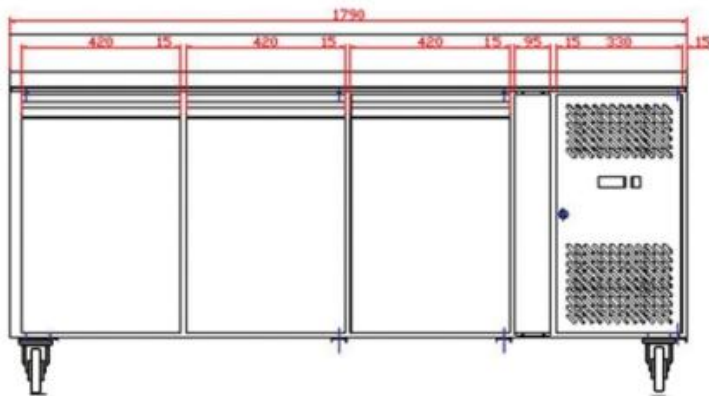
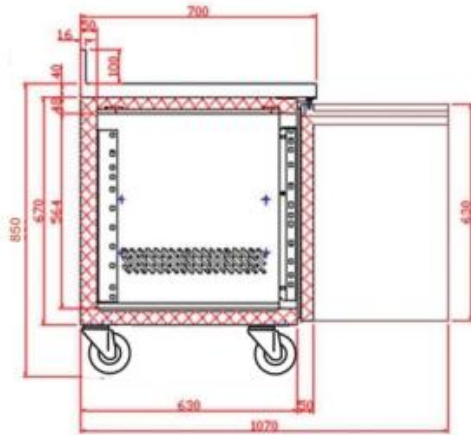

Food Equipment (NZ) Ltd

1066 Hinemoa Street, Rotorua

P.O. Box 10067, Rotorua, New Zealand

(07) 3488430

