

# Specification FE-G35-KA18

Item: \_\_\_\_\_  
 Quantity: \_\_\_\_\_  
 Project: \_\_\_\_\_

## INDUCTION COOKTOPS

### Models

FE-G35-KA18 Single hobs, Manual Control



FE-G35-KA18

### FEATURES

- German IGBT
- Stainless Steel framed hobs
- Overheat system protection
- Five commercial high-flow fans
- 90% efficiency rating
- Rubber feet to prevent slipping

### MANUAL CONTROL MODELS

- 3500W, 220-240V/50Hz
- Power control, from level 1 to level 10
- Timer control, from 1-24 hours

### DESCRIPTION

These high-efficiency, heavy-duty, commercial induction cooktops are designed for use in commercial kitchens. They provide sensitive control for fast, high temperature cooking.

The induction cooktops come complete with power cords. The case is made from 201 stainless steel with a grade-A ceramic top. The ceramic top is easily cleaned with a mild cleaner.

The induction range is equipped with a variety of safety features including:

- Over-heat protection
- Small-article detection
- Pan auto-detection function
- Empty-pan shut-off

### IMPORTANT

This appliance is intended for use with induction-ready cookware. All units requires a minimum clearance of four 4"(101.6mm) between all sides of the housing and any surface or obstacle. Avoid ambient temperatures exceeding 50°C/122°F.

### WARRANTY:

All models shown come with standard warranty against defects in materials and

### AGENCY LISTING

**CB CE** This device complies with CB,CE Standards.

### Food Equipment (NZ) Ltd

1066 Hinemoa St PO Box 10067 Rotorua, New Zealand

www.foodequipment.co.nz |Phone:(07) 3488430

## Model FE-G35-KA18

### Model FE-G35-KA18

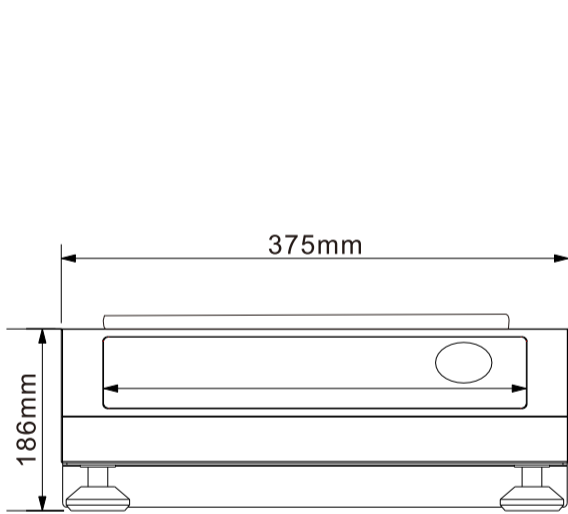

Front View

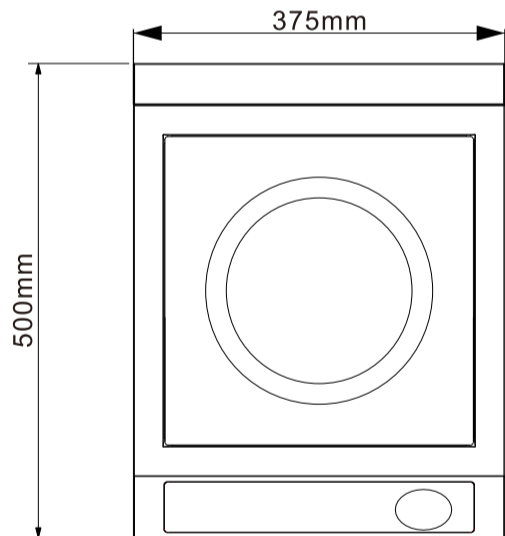

Top View

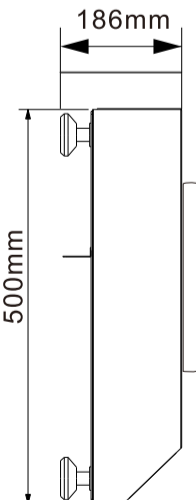

Side View

Model	Volts	Watts	Plug	Amp
FE-G35-KA18	240V	3500	YES	15A

Plug Configurations		
Model	Electrical Characteristics	Plug
FE-G35-KA18	240V/50Hz 3500W	

### Food Equipment (NZ) Ltd

1066 Hinemoa St PO Box 10067 Rotorua, New Zealand

www.foodequipment.co.nz |Phone:(07) 3488430